

SHARP SERVICE MANUAL

CODE:00ZPCE500SM/E



PC-E

MODEL PC-E500

1. Product outline

The PC-E500 employs the large display (40 digits x 4 lines) and 32KB memory (standard).

2. Specifications

Model name	: PC-E500
Display	: 40 digits x 4 lines (5 x 7 dot matrix liquid crystal display)
Calculation digit	: Single accuracy calculation; 10 digits (Mantissa) + 2 digits (Exponent) Double accuracy calculation; 20 digits (Mantissa) + 2 digits (Exponent) In CAL, MATRIX, or STAT mode, calculation is performed in single accuracy.
Calculation system	: In the sequence of formula. (Priority judgement function)
Program language	: BASIC
CPU	: CMOS 8 bit CPU
System ROM	: 128 K Byte
Memory capacity	: System area about 3.8 K Byte Fixed variable (A - Z) area 312 Byte Program data area 28600 Byte
Stack	: Total 145 Byte Subroutine; 4 Byte for one stage FOR-NEXT; 21 Byte for one stage
Basic calculation functions	: Basic calculations; Addition, subtraction, multiplication, division Functional calculation; Trigonometric function, reverse trigonometric function, hyperbolic function, reverse hyperbolic function, logarithm, exponent, angle conversion, power, power root, coordinate conversion, extraction of the square root, integration, absolute value, code function, pi, etc.

Edit function	: Cursor shift, right/left (◀, ▶) Insertion (INS) Delete (DEL, BS) Line up, down (↑, ↓)
Serial I/O machine	
Communication system	: Start-stop synchronous (asynchronous) system, half duplex/total duplex mode
Communication speed	: 300, 600, 1200, 2400, 4800, 9600bps (bit per second)
Parity bit	: Even number, odd number, none
Word length	: 7, 8 bit
Stop bit	: 1, 2 bit
Connector	: 15-pin connector (for connection with external devices)
Output signal level	: C-MOS level (4 - 6V)
Interface signal	: Input RD, CS, CD Output SD, RS, RR, ER Others SG, FG, VC
Memory protection	: Battery backup (Backups the program and data when the power is turned off.)
Operating temperature	: 0 - 40°C
Power source	: DC 6V (R03 x 4)
Battery operating time	: About 70 hours of continuous operation (Under the operating temperature of 20°C, 10 minutes of calculation or program execution and 50 minutes of display for every hour) • There may be some variation depending on the operating environment and using conditions.
Power consumption	: 0.07W
External dimension	: 200mm (W) x 100mm (D) x 14mm (H)
Weight	: 250g (Including the battery)
Accessories	: Hard cover, R03 battery x 4, Instruction Manual

3. System configuration

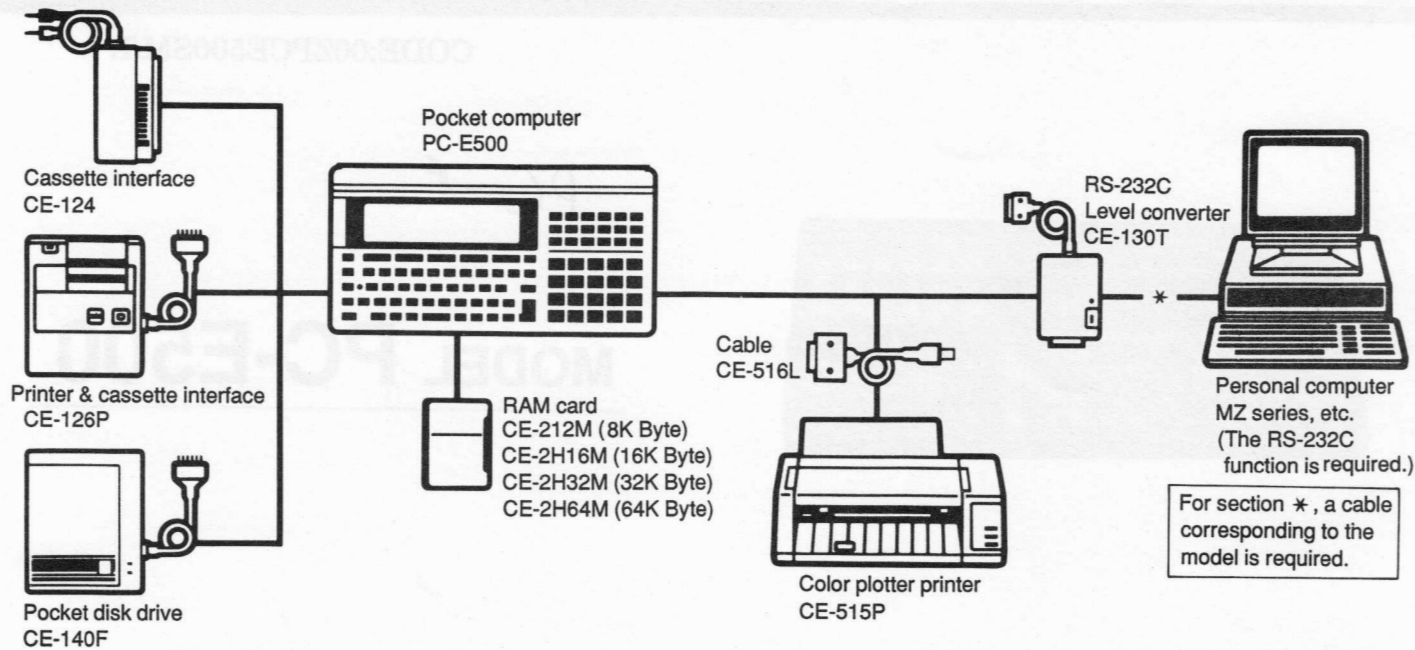

4. PC-E500 system block diagram

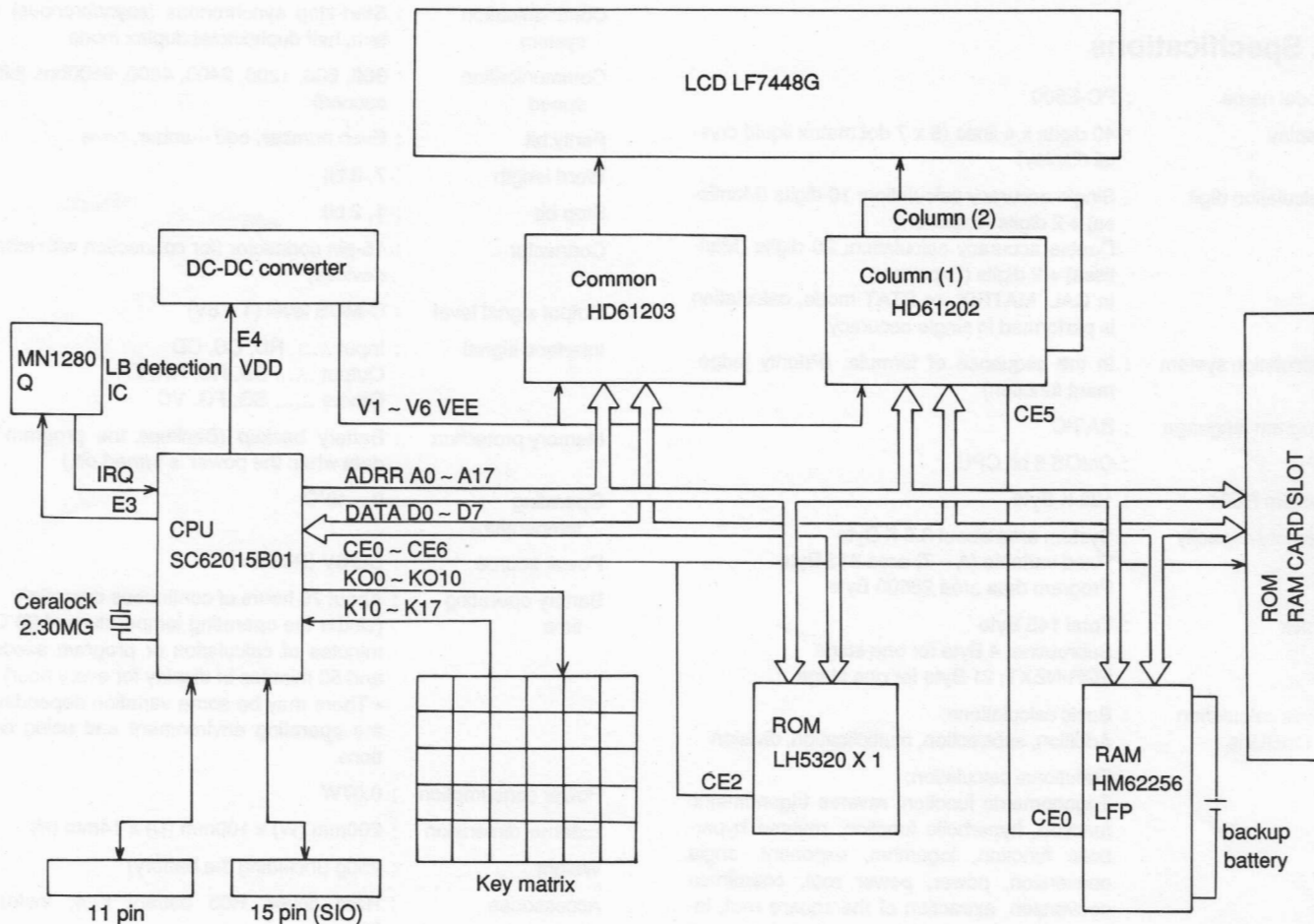

5. Memory map

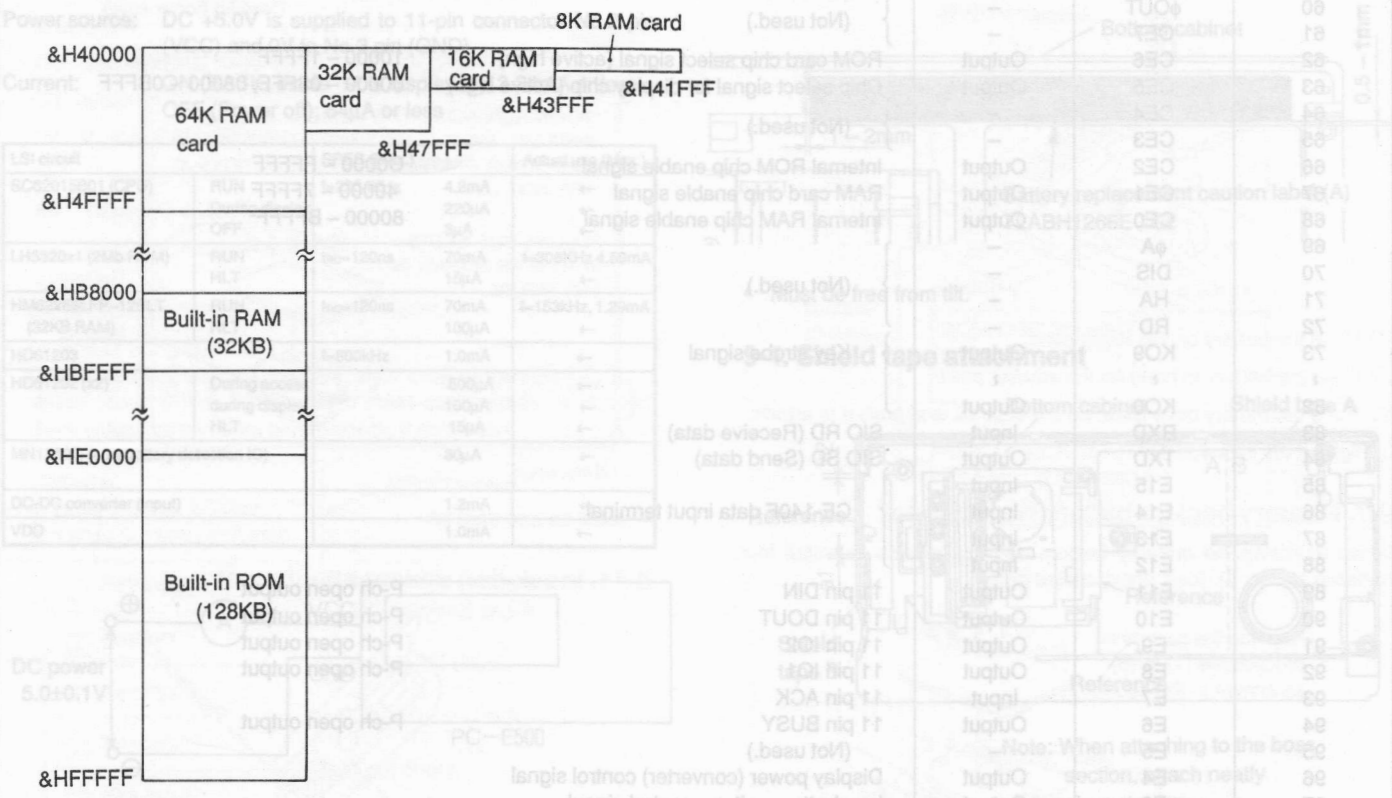

6. LSI description

CPU (SC62015) terminal signal description

Terminal No.	Signal name	Input/Output	Signal description
1	X1	Output	Ceramic oscillation output
2	X2	Input	Ceramic oscillation input
3	X3	Output	CR oscillation output
4	X4	Input	CR oscillation input
5	VDD	Output	Display power (converter) control output
6	VCC	Power	⊕ power input terminal
7	RESET	Input	Reset input. Reset at high level.
8	GND	Power	⊖ power input terminal
9	TEST	Input	Test input
10	CI	Input	Cassette signal input terminal
11	CO	Output	Cassette signal output terminal
12	ON	Input	ON key input terminal. Normally pulled down to low level.
13	WR	Output	Write clock. Normally high level.
14	MRQ	-	(Not used.)
15	K10	Input	Key input terminal
22	K17	Input	
23	DIO0	I/O	
30	DIO7	I/O	Data bus
31	A0	Output	
49	A18	Output	
50	VDISP	-	Address bus
51	VA	-	
52	φD	Output	
53	KO15	Output	(Not used.)
54	KO14	Output	
55	KO13	Output	
56	KO12	Output	Key stroke signal
57	KO11	Output	
58	KO10	Output	
59	IRQ	Input	Low battery detection input terminal

Terminal No.	Signal name	Input/Output	Signal description	
60	ϕ OUT	-	} (Not used.)	
61	CE7	-		
62	CE6	Output	ROM card chip select signal (active high)	10000 ~ 1FFFF
63	CE5	Output	Chip select signal for display chip (Active high)	00000 ~ 03FFF, 08000 ~ 0BFFF
64	CE4	-	} (Not used.)	
65	CE3	-		
66	CE2	Output	Internal ROM chip enable signal	C0000 ~ FFFFF
67	CE1	Output	RAM card chip enable signal	40000 ~ 7FFFF
68	CE0	Output	Internal RAM chip enable signal	80000 ~ BFFFF
69	ϕ A	-	} (Not used.)	
70	DIS	-		
71	HA	-		
72	RD	-		
73	KO9	Output	} Key strobe signal	
82	KO0	Output		
83	RXD	Input	SIO RD (Receive data)	
84	TXD	Output	SIO SD (Send data)	
85	E15	Input	} CE-140F data input terminal	
86	E14	Input		
87	E13	Input		
88	E12	Input		
89	E11	Output		11 pin DIN
90	E10	Output	11 pin DOUT	P-ch open output
91	E9	Output	11 pin IO2	P-ch open output
92	E8	Output	11 pin IO1	P-ch open output
93	E7	Input	11 pin ACK	
94	E6	Output	11 pin BUSY	P-ch open output
95	E5	-	(Not used.)	
96	E4	Output	Display power (converter) control signal	
97	E3	Output	Low battery voltage control signal	
98	E2	Input	SIO CS (Opponent side send enable)	
99	E1	Input	SIO CD (Opponent side send request)	
100	E0	Input	SIO PAK (Not used.)	

7. Low battery detection circuit

The PC-E500 is equipped with the low battery detection circuit. The operations of the circuit are described below. (Part location numbers may differ from those in the actual circuit diagram.)

When input voltage V_{IN} exceeds the detection voltage V_D , the output of the voltage detection IC [LBIC(MN1280)] is driven from Low to High. When V_{IN} falls under V_D , the output is driven from High to Low.

The LBIC (MN1280) detects both the CAU level and the STOP level by dividing the voltage applied to the input terminal (2 pin) with R1 and R2 and by turning on/off R2 with CAU signal of G-A.

When the power voltage falls under the CAU level, as shown in Fig. 3, the BATT symbol lights up. When the power voltage falls further under the STOP level, the symbol goes off.

For CAU level detection, the CPU E3 is turned on (low level) and the CPU IRQ terminal state is observed. (If the IRQ is at Low level, the symbol lights up.)

When the CAU level is detected, the CPU E3 terminal is turned off (high impedance). (When the CPU E3 terminal is turned off, resistor division is not performed and the voltage at LBIC 2 pin increases, driving the output from Low to High.) The CPU IRQ terminal state is checked again to detect the STOP level

After the STOP level is detected, the ON key and the RESET key become ineffective.

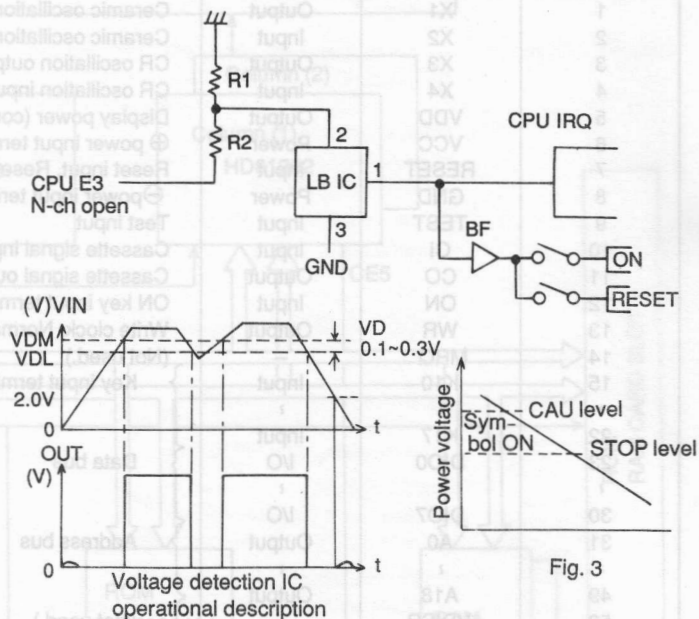

Low battery detection circuit check

CAU level VCC - GND: 4.2V to 4.6V
 STOP level VCC - GND: 3.8V to 4.2V

8. Current consumption check

Power source: DC +5.0V is supplied to 11-pin connector No.2 pin (VCC) and 0V to No.3 pin (GND).

Current: ON (BASIC mode ">" is displayed); 3.24mA or less
OFF (Power off); 64µA or less

LSI circuit		SPEC (Max.)	Actual use (Max.)
SC62015B01 (CPU)	RUN	f=2304KHz	4.2mA ←
	During display		220µA ←
	OFF		3µA ←
LH5320x1 (2Mb ROM)	RUN	t _{RC} =120ns	70mA ←
	HLT		15µA ←
HM62256LFP-12SLT (32KB RAM)	RUN	t _{RC} =120ns	70mA ←
	HLT		100µA ←
HD61203		f=600kHz	1.0mA ←
HD61202 (x2)	During access		500µA ←
	during display		100µA ←
	HLT		15µA ←
MN1280Q (Low battery detection IC)			30µA ←
DC-DC converter (input)			1.2mA ←
VDD			1.0mA ←

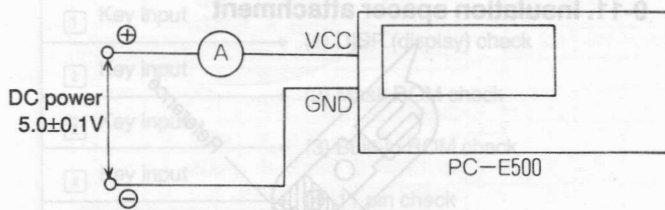

9. Note for servicing

9-1. Battery holding cushion attachment

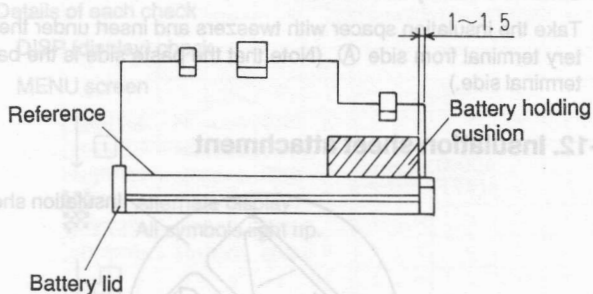

9-2. Battery holding cushion attachment

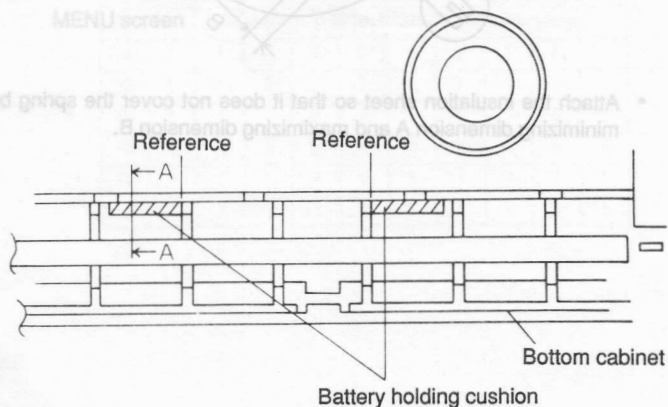

9-3. Battery replacement label attachment

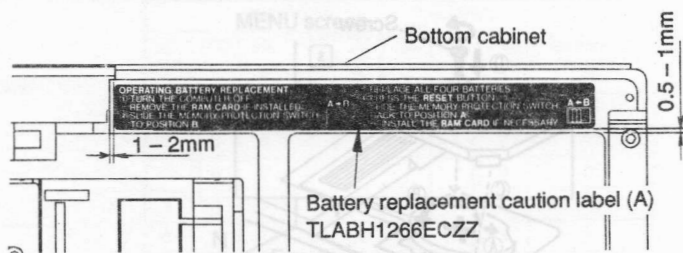

- Must be free from tilt.

9-4. Shield tape attachment

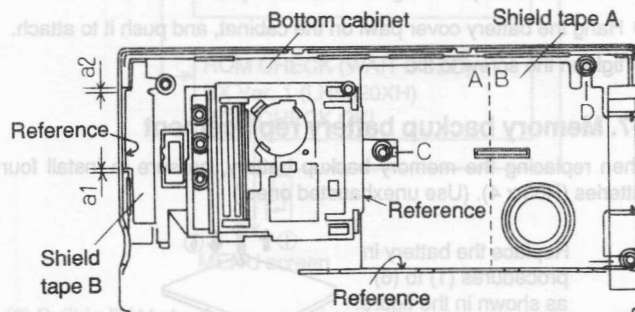

Note: When attaching to the boss section, attach neatly along the boss.

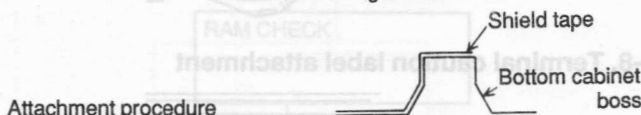

Attachment procedure

Shield tape A

- 1) Remove the separation paper in side B, and bend section C and D as shown below.
- 2) Fit the A side with the reference, and paste the B side.
- 3) Remove the separation paper, and attach the tape.

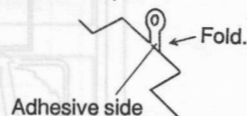

- 4) Attach the three boss sections. (Fit the boss holes with the shield tape holes.)
- 5) Attach the tape so that there is no slack.

Shield tape B

- 1) Bend E section. (Similar to C section.)
- 2) Fit with the reference and attach so that a1 and a2 are even.
- 3) Attach the boss section. (Fit the boss hole and the shield tape hole.)
- 4) Attach the tape so that there is no slack.

9-5. Main PWB replacement procedure

- ① Press the OFF key. (If a RAM card is installed, remove it.)
- ② Switch the select switch from A to B.
- ③ Replace all the four batteries with new ones.
- ④ Press the RESET switch.
- ⑤ Switch the select switch from B to A. (Install the RAM card.)



9-6. Memory backup battery cover attachment

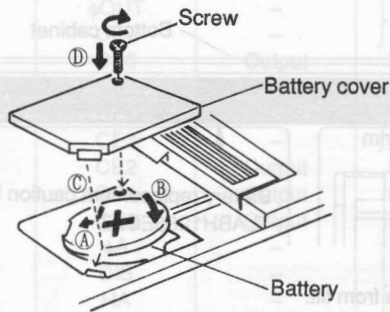

- Ⓐ Hang the battery on the larger pawl.
- Ⓑ Push the battery to hang on the smaller pawl.
- Ⓒ Hang the battery cover pawl on the cabinet, and push it to attach.
- Ⓓ tighten the screw to fix.

9-7. Memory backup battery replacement

When replacing the memory backup battery, be sure to install four batteries (R03 x 4). (Use unexhausted ones.)

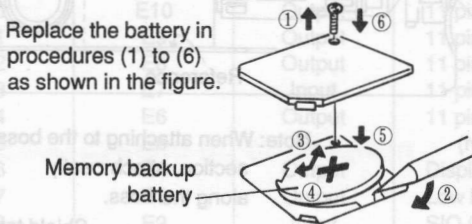

Replace the battery in procedures (1) to (6) as shown in the figure.

9-8. Terminal caution label attachment

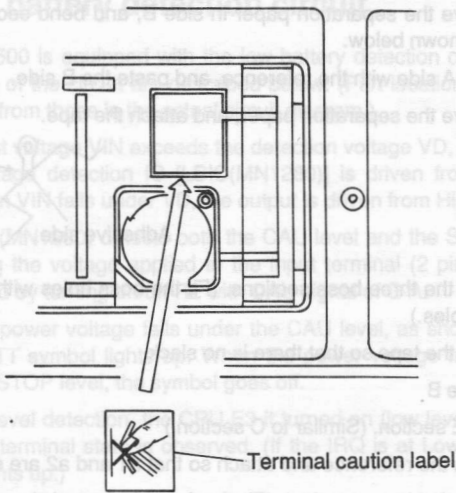

* Paste the label correctly in position.

9-9. Battery insulation sheet attachment

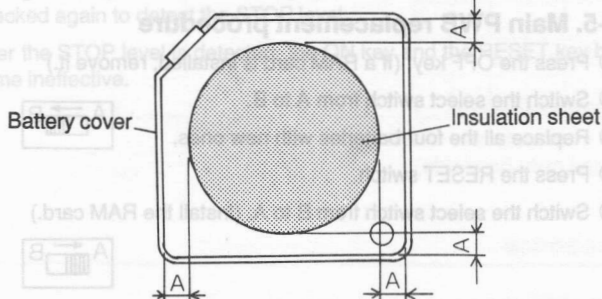

Attach the insulation sheet to the center so that dimensions A (4 positions) are all the same.

9-10. Battery replacement label B attachment

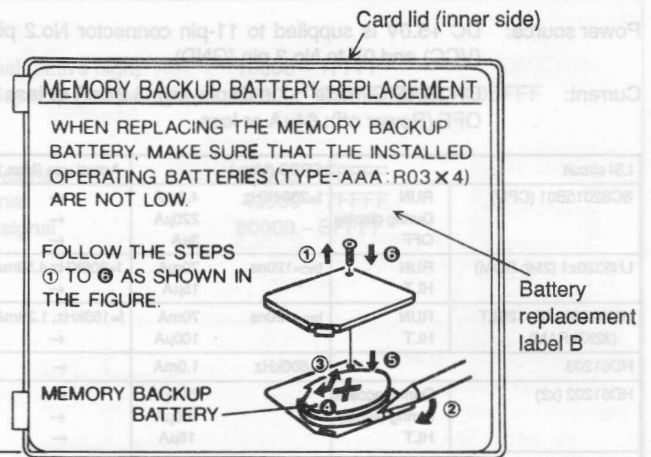

Reference

- Must be free from tilt.

9-11. Insulation spacer attachment

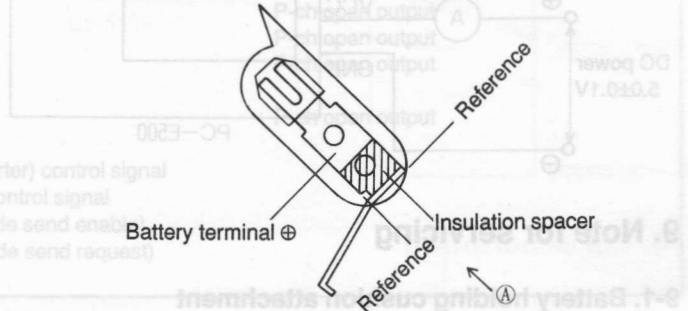

- 1) Solder the battery terminal ⊕.
- 2) Take the insulation spacer with tweezers and insert under the battery terminal from side Ⓐ. (Note that the paste side is the battery terminal side.)

9-12. Insulation sheet attachment

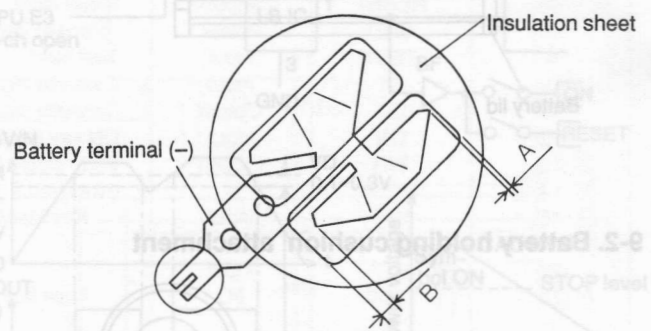

- Attach the insulation sheet so that it does not cover the spring by minimizing dimension A and maximizing dimension B.

10. Check software for servicing

- Check item
 - (1) Liquid crystal visual check (alternate display)
 - (2) Mask ROM verify check
 - (3) Built-in RAM read/write check
 - (4) 11 pin I/O check
 - (5) 15 pin I/O check
 - (6) RAM card read/write check
- Required tools
Jig UKOGC3020CSZZ: Used for (4) and (5).
- Outline of using method
Before inputting a check software, clear the RAM completely.
When check (6) is executed, the RAM card content is deleted.
Save programs and data before check, if necessary.

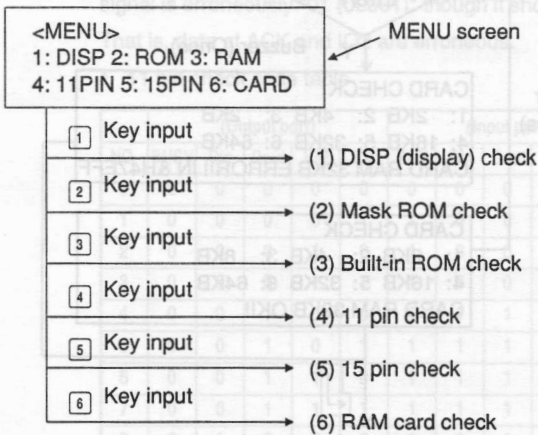

Note: To end a check, press the BRK[ON] key.

- Details of each check
- (1) DISP (display) check

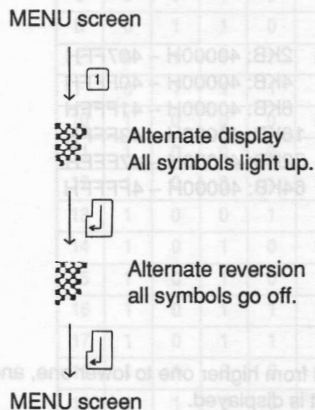

(2) Mask ROM check

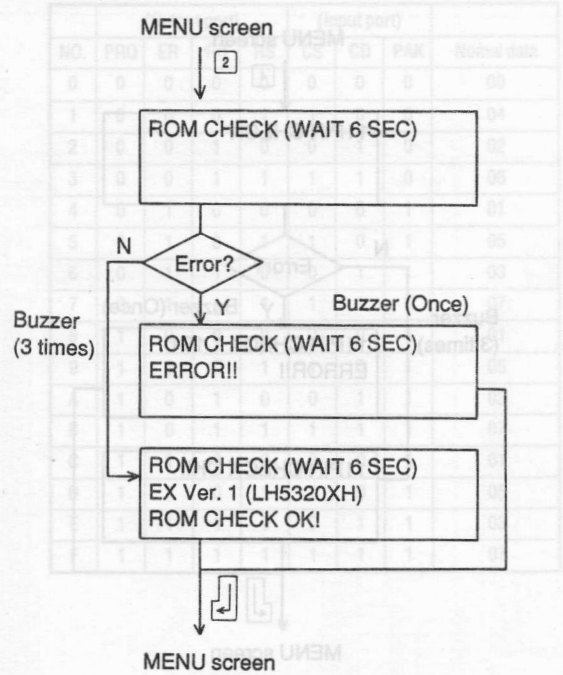

(3) Built-in RAM check

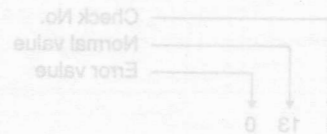
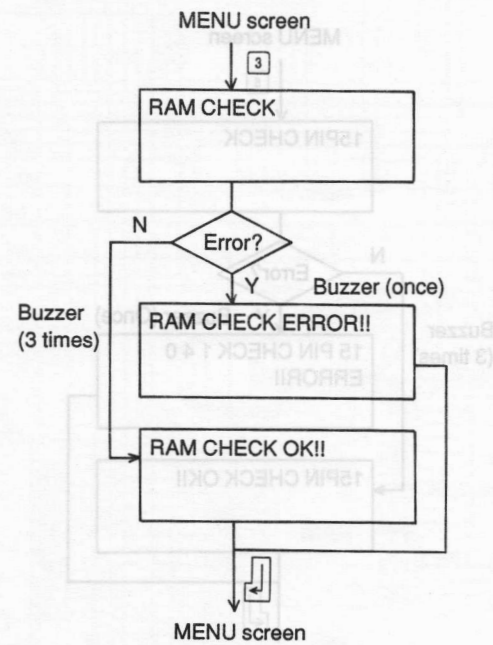

(4) 11 pin check

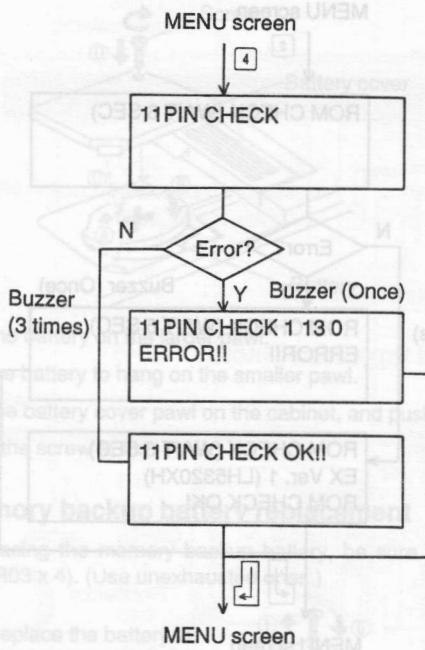

(5) 15 pin check

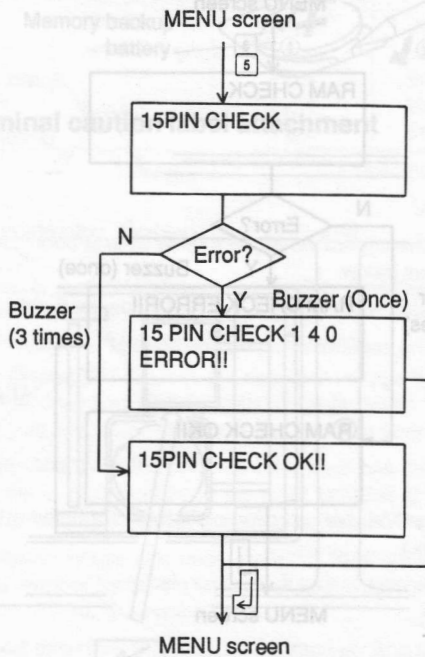

- The error code in 11 pin check or 15 pin check means as follows:

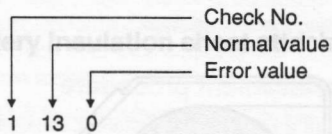

- For details of error, see "Error code description".

(6) RAM card check

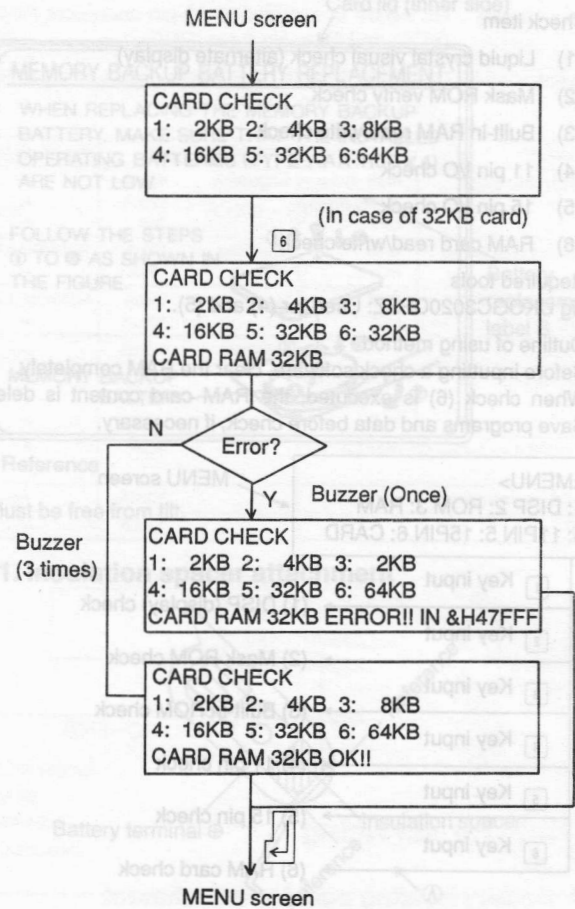

• RAM card address map

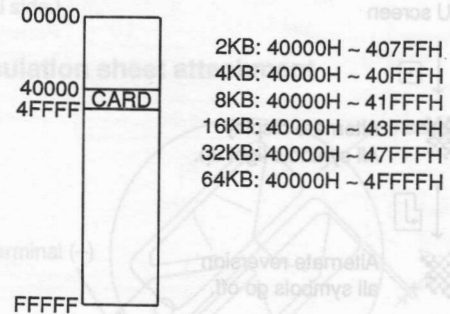

- Addresses are checked from higher one to lower one, and the error address found first is displayed.

• Error code description

(Example) In 11 pin check error:

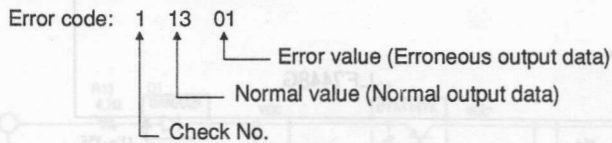

See the 11 pin check code table.

NO	(Output port)					(Input port)					Normal data	
	BUSY	Din	Dout	IO2	IO1	ACK	Din	Dout	IO2	IO1		
0	0	0	0	0	0	1	1	0	0	1	1	13

The above table shows that input port signal "10011" is normal when output port signal is "000001." ("10011" is a binary number which is converted into "13" in hexadecimal number system.)

When 11 pin check error code is "1 13 01," it shows that input port signal is erroneously "01 (00001)" though it should be "13 (10011)."

That is, data at ACK and IO2 are erroneous.

• 11 pin check code table

NO.	(Output port)					(Input port)					Normal data	
	BUSY	Din	Dout	IO2	IO1	ACK	Din	Dout	IO2	IO1		
0	0	0	0	0	0	0	0	0	0	0	0	00
1	0	0	0	0	0	1	1	0	0	1	1	13
2	0	0	0	0	1	0	1	0	0	1	1	13
3	0	0	0	0	1	1	1	0	0	1	1	13
4	0	0	1	0	0	1	1	1	0	0	0	1C
5	0	0	1	0	1	1	1	1	1	1	1	1F
6	0	0	1	1	0	1	1	1	1	1	1	1F
7	0	0	1	1	1	1	1	1	1	1	1	1F
8	0	1	0	0	0	1	1	1	0	0	0	1C
9	0	1	0	0	1	1	1	1	1	1	1	1F
A	0	1	0	1	0	1	1	1	1	1	1	1F
B	0	1	0	1	1	1	1	1	1	1	1	1F
C	0	1	1	0	0	1	1	1	0	0	0	1C
D	0	1	1	0	1	1	1	1	1	1	1	1F
E	0	1	1	1	0	1	1	1	1	1	1	1F
F	0	1	1	1	1	1	1	1	1	1	1	1F
10	1	0	0	0	0	1	0	0	0	0	0	10
11	1	0	0	0	1	1	0	0	1	1	1	13
12	1	0	0	1	0	1	0	0	1	1	1	13
13	1	0	0	1	1	1	0	0	1	1	1	13
14	1	0	1	0	0	1	1	1	0	0	0	1C
15	1	0	1	0	1	1	1	1	1	1	1	1F
16	1	0	1	1	0	1	1	1	1	1	1	1F
17	1	0	1	1	1	1	1	1	1	1	1	1F
18	1	1	0	0	0	1	1	1	0	0	0	1C
19	1	1	0	0	1	1	1	1	1	1	1	1F
1A	1	1	0	1	0	1	1	1	1	1	1	1F
1B	1	1	0	1	1	1	1	1	1	1	1	1F
1C	1	1	1	0	0	1	1	1	0	0	0	1C
1D	1	1	1	0	1	1	1	1	1	1	1	1F
1E	1	1	1	1	0	1	1	1	1	1	1	1F
1F	1	1	1	1	1	1	1	1	1	1	1	1F

• 15 pin check code table

NO.	(Output port)					(Input port)			Normal data
	PRQ	ER	RR	RS	CS	CD	PAK		
0	0	0	0	0	0	0	0	0	00
1	0	0	0	1	1	0	0	0	04
2	0	0	1	0	0	1	0	0	02
3	0	0	1	1	1	1	0	0	06
4	0	1	0	0	0	0	1	0	01
5	0	1	0	1	1	0	1	0	05
6	0	1	1	0	0	1	1	0	03
7	0	1	1	1	1	1	1	0	07
8	1	0	0	0	0	0	1	0	01
9	1	0	0	1	1	0	1	0	05
A	1	0	1	0	0	1	1	0	03
B	1	0	1	1	1	1	1	0	07
C	1	1	0	0	0	0	1	0	01
D	1	1	0	1	1	0	1	0	05
E	1	1	1	0	0	1	1	0	03
F	1	1	1	1	1	1	1	0	07

• Check software

```

10: ARUN
20: IF PEEK &BFD1A+PEEK &
   BFD1B*%100+PEEK &BFD1
   C*%10000<>%BFC00 THEN
   *A
30: POKE &BFE03,&1A:&FD,&
   0B,&00,&05:&00:CALL &
   FFD8
40: *A:CLS:PRINT "<MENU>"
50: PRINT "1:DISP 2:ROM
   3:RAM
60: PRINT "4:11PIN 5:15PI
   N 6:CARD
70: A=VAL INKEY$
80: IF A<10R A>6 THEN 70
90: ON A GOSUB *B,*C,*D,*
   E,*F,*G
100: GOTO *A
110: *B:=&BFC97:S=PEEK B
   T=PEEK (B+1):U=PEEK
   (B+2):V=PEEK (B+3)
120: A$="55AA":C=255:GOSU
   B *H:GOSUB *I
130: A$="A555":C=0:GOSUB
   *H:GOSUB *I
140: POKE B,S:U,V
150: RETURN
160: *H:POKE B,C:C,C
170: CLS:FOR I=1 TO 4:GCU
   =0 TO 119:GPRINT A$;
   NEXT:NEXT
180: RETURN
190: *C:CLS:PRINT "ROM C
   HECK (WAIT 6 SEC)"
200: M=&BEE0:GOSUB *J:CA
   LL M
210: B$="":A$=HEX$ PEEK (
   M-1)+HEX$ PEEK (M-2)
220: IF A$="5C7E"LET B$="
   135"
230: IF A$="DC78"LET B$="
   122"
240: IF A$="350E"LET B$="
   111"
250: IF A$="A05A"LET B$="
   10"
260: IF A$="9944"LET B$="
   21H"
270: IF A$="B0DC"LET B$="
   20D"
280: IF B$="BEEP 1:PRINT
   "ROM ERROR!":GOTO *
   I
290: IF B$<"2"PRINT "JAPA
   N ":GOTO 310
300: PRINT "EX ";
310: PRINT "Ver.":MID$(B
   $,2,1):"(LH5320X":RI
   GHT$(B$,1):")":BEEP
   3:PRINT "ROM CHECK
   OK!"
320: GOTO *I
330: *J:POKE M:&0C,&00,&0
   0,&0C,&09,&00,&0A,&0
   0,&00,&09,&04,&4,&3
   0,&0C,&04,&1B,&03,&A
   B,&DE,&EE:&0B,&07,&0
   0,&00,&00,&00,&00,&0
   0,&00,&00,&20,&AB
340: RETURN
350: *D:CLS:PRINT "RAM C
   HECK ";
360: POKE &5D:0,&90:&B,0,
   &DC:&B
370: M=&BEE0:GOSUB *K:CA
   LL M
380: IF PEEK &66=0BEEP 3:
   PRINT "OK!":GOTO *I
390: BEEP 1:PRINT "ERROR!
   ! IN &H":HEX$ PEEK &
   65+RIGHT$( "0"HEX$
   PEEK &64,2)+HEX$ PEE
   K &63
400: GOTO *I
410: *E:CLS:PRINT "11PIN
   CHECK ";
420: RESTORE *L
430: D=PEEK &F3:E=PEEK &F
   4
440: POKE &F3,D AND &BF
450: *Y:FOR I=0 TO 15
460: POKE &F4,I
470: F=PEEK &F5:G=PEEK &F
   6
480: J=(F AND &80)>8+(G A
   ND &F0)>16
490: READ K
500: IF J<K THEN PRINT H
   EX (I):HEX (K):HEX (
   J):GOTO *M
510: NEXT
520: IF Z=1 THEN *Z
530: Z=1:POKE &F3,D OR 64
540: GOTO *Y
550: *Z:POKE &BFCBF,64
560: L=PEEK &D:POKE &FD,
   ((L AND &8F)+80):M=P
   EEK &FF
570: IF (M AND 2) THEN *S
   ELSE *M
580: *S:POKE &FD,((L AND
   &8F)+64):M=PEEK &FF
590: IF (M AND 2) THEN *M
600: BEEP 3:PRINT "OK!"
610: GOTO *N
620: *L:DATA 0,19,19,19,2
   8,31,31,31,28,31,31,
   31,28,31,31,31,16,19
   19,19,28,31,31,31,2
   8,31,31,31,28,31,31,
   31
630: *M:BEEP 1:PRINT "ERR
   OR!"
640: POKE &F3,D,E:POKE &F
   D,L
650: *N:GOTO *I
660: *F:CLS:RESTORE *O:P
   RINT "15PIN CHECK ";
670: F1=(PEEK &F1)AND 15
680: FOR I=0 TO 15
690: POKE &F1,F1+16*I
700: READ S101
710: S102=((PEEK &F5) AND
   7)
720: IF S101=S102 THEN 73
   0 ELSE PRINT HEX (I)
   :HEX (S101):HEX (S10
   2):GOTO *O
730: NEXT
740: POKE &F1,F1
750: F7=PEEK &F7:F8=PEEK
   &F8:F9=PEEK &F9:F8=P
   EEK &FB
760: POKE &FB,&8F:POKE &F
   7,&3C
770: FOR I=1 TO 100:NEXT
   X$ PEEK &64,2)+HEX$
   PEEK &63
780: F8=PEEK &F8
790: IF (F8 AND 32) THEN P
   RINT "RD HIGH ";GOT
   O *P
800: POKE &F7,&BC
810: FOR I=1 TO 100:NEXT
   (L AND &8F)+80):M=P
820: F8=PEEK &F8
830: IF (F8 AND 4)=4 THEN
   840 ELSE PRINT "RD L
   OW ":GOTO *P
840: POKE &FB,F8:POKE &F7
   ,F7
850: BEEP 3:PRINT "OK!"
860: GOTO *I
870: *O:DATA 0,4,2,6,1,5,
   3,7,1,5,3,7,1,5,3,7
880: *P:POKE &FB,F8:POKE
   &F7,F7
890: *O:BEEP 1:PRINT "ERR
   OR!"
900: GOTO *I
910: *G:CLS:PRINT "CARD
   CHECK"
920: IF INKEY$ (>)" THEN *
   G
930: PRINT "1: 2KB 2: 4K
   B 3: 8KB
940: PRINT "4: 16KB 5: 32K
   B 6: 64KB
950: *R:A$=INKEY$:IF A$<
   "1"OR A$>"6" THEN *R
   ^VAL A$+4-1,4
960: POKE &5D,0,0,4,255,2
970: M=&BEE0:GOSUB *K
980: PRINT "CARD RAM":STR
   $(2*VAL A$);"KB ";
990: CALL M
1000: IF PEEK &66=0BEEP 3
   :PRINT "OK!":GOTO
   *I
1010: BEEP 1:PRINT "ERROR
   ! IN &H":HEX$ PEEK
   &65+RIGHT$( "0"HE
   X$ PEEK &64,2)+HEX$
   PEEK &63
1020: GOTO *I
1030: *K:POKE M:&08,&FF,&
   32,&84,&60,&B0,&04,
   &32:&A4,&53,&7C:&04
   ,&49,&01,&60,&01,&1
   A,&02,&48:&01,&32,&
   C7,&63,&5D,&1B,&15,
   &08,&FF,&32,&84,&60
   ,&32
1040: POKE M+&20,&A4,&63,
   &32:&E0,&04,&67,&32
   ,&63,&67,&1A,&14,&87
   C,&04,&48:&01,&60,&
   01,&1A,&08,&48,&01,
   &32,&C7,&63,&5D,&1B
   ,&1C,&08,&00,&12,&00
   2,&08
1050: POKE M+&40,&01,&32,
   &A0,&66,&3F,&07
1060: RETURN
1070: *I
1080: IF INKEY$ =" " THEN *
   I
1090: RETURN

```

11. Circuit diagram

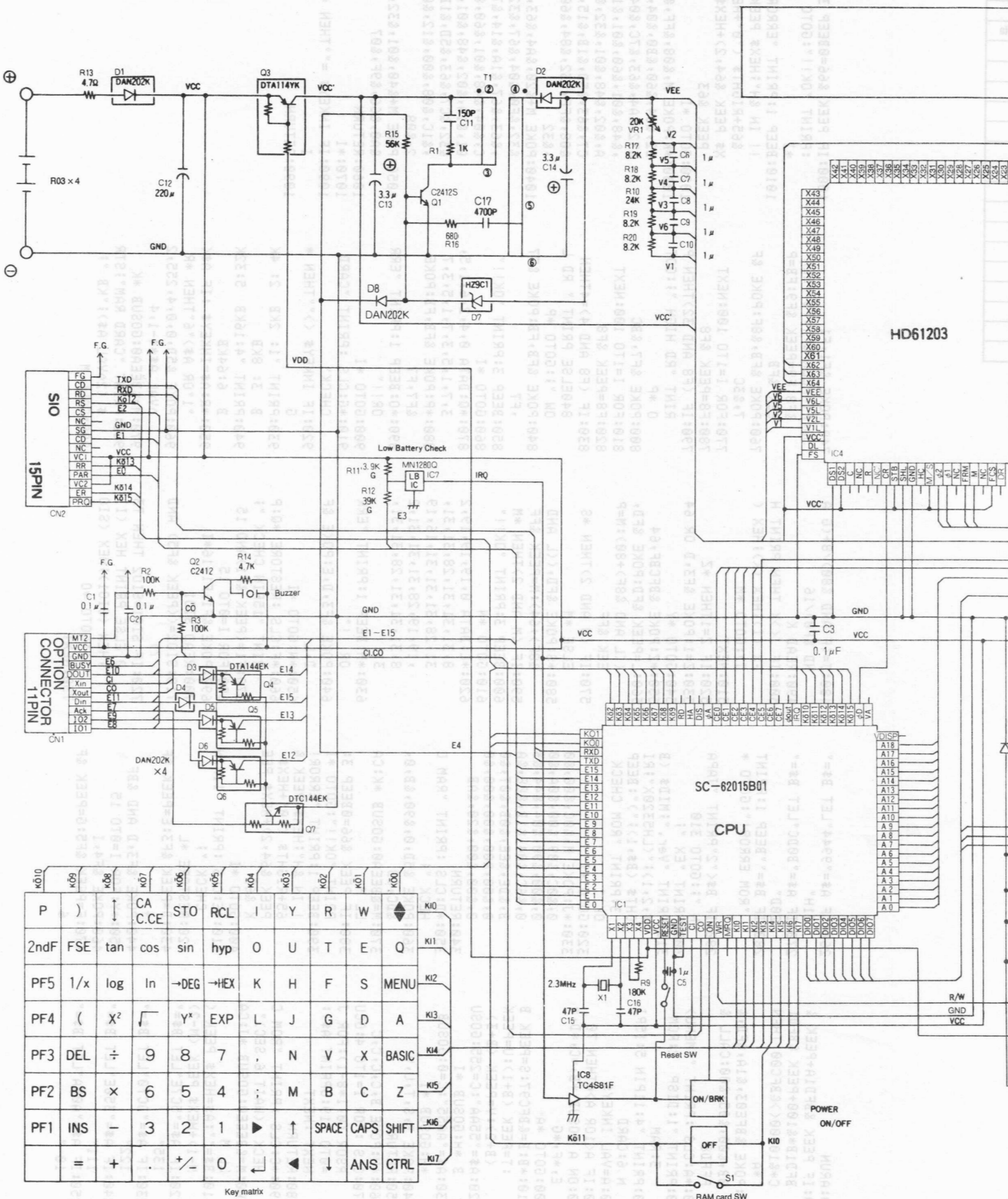

K010	K09	K08	K07	K06	K05	K04	K03	K02	K01	K00
P)	↑	CA C.CE	STO	RCL	I	Y	R	W	◀
2ndF	FSE	tan	cos	sin	hyp	O	U	T	E	Q
PF5	1/x	log	In	→DEG	→HEX	K	H	F	S	MENU
PF4	(X ²	√	Y ^x	EXP	L	J	G	D	A
PF3	DEL	÷	9	8	7	.	N	V	X	BASIC
PF2	BS	×	6	5	4	;	M	B	C	Z
PF1	INS	-	3	2	1	▶	↑	SPACE	CAPS	SHIFT
	=	+	+/-	0	◀	◀	↓	ANS	CTRL	

Key matrix

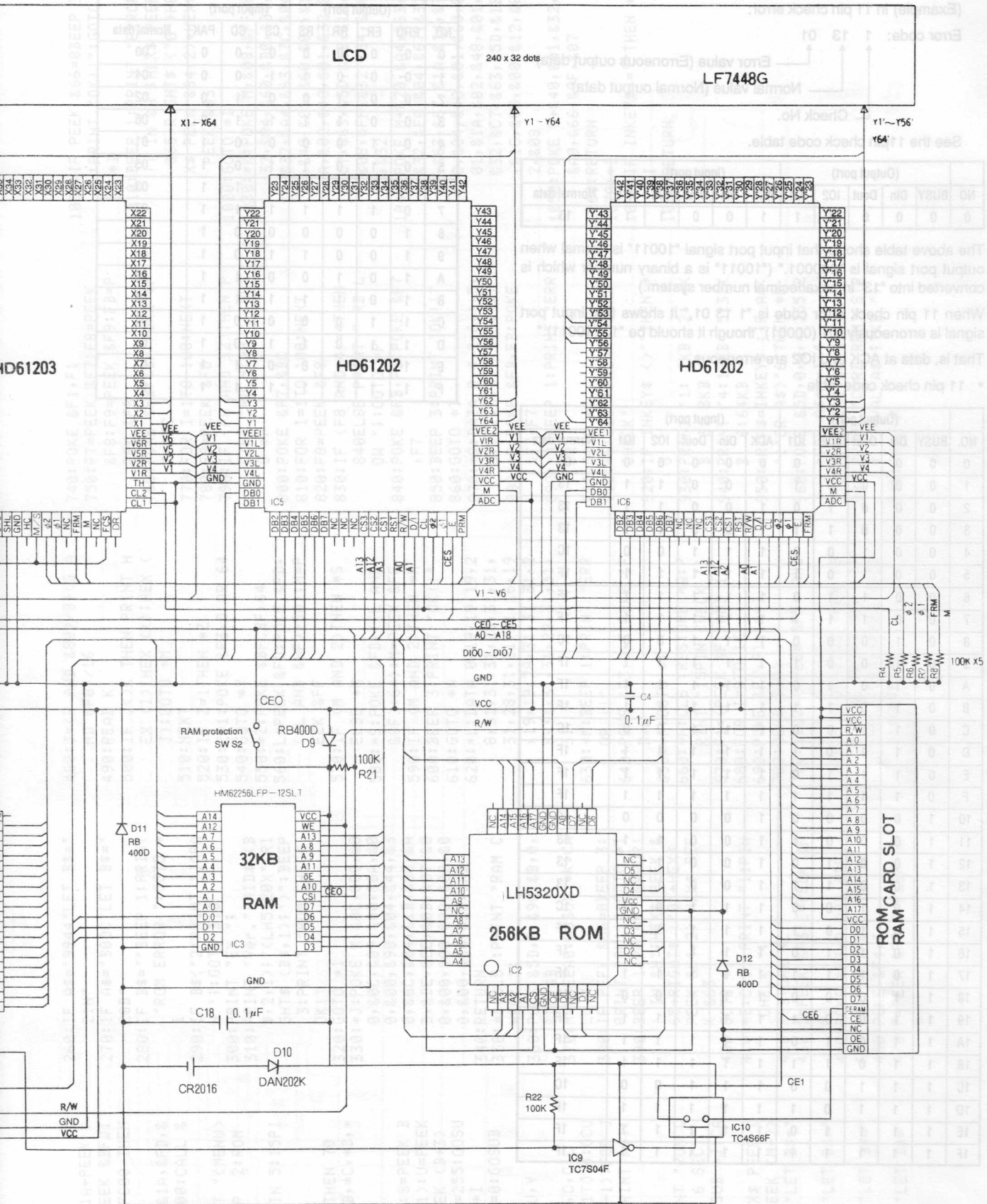

12. LCD wiring diagram

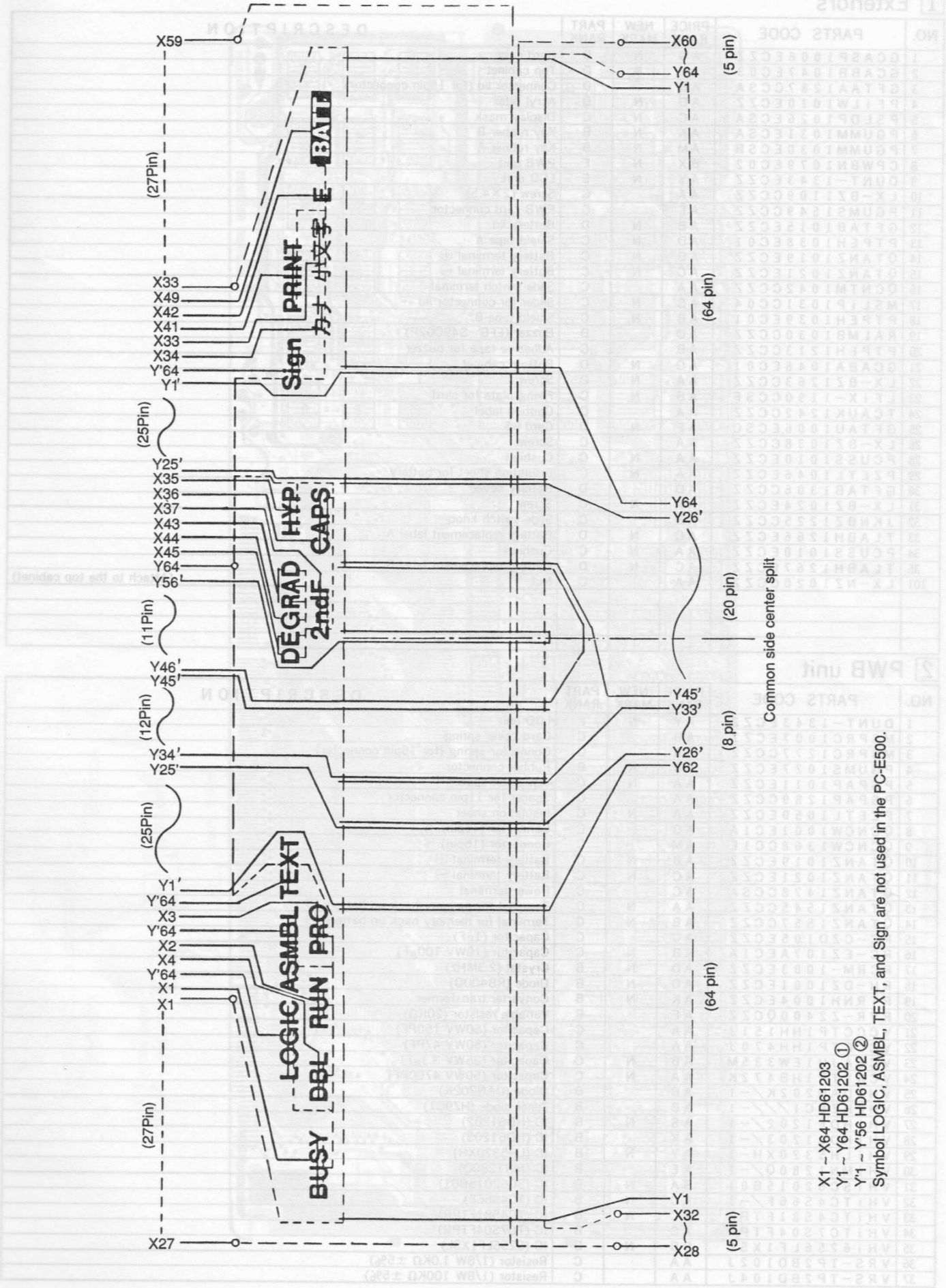

X1 - X64 HD61203
 Y1 - Y64 HD61202 ①
 Y'1 - Y'56 HD61202 ②
 Symbol LOGIC, ASMBL, TEXT, and Sign are not used in the PC-E500.

13. Parts signals arrangement

13-1. Parts side

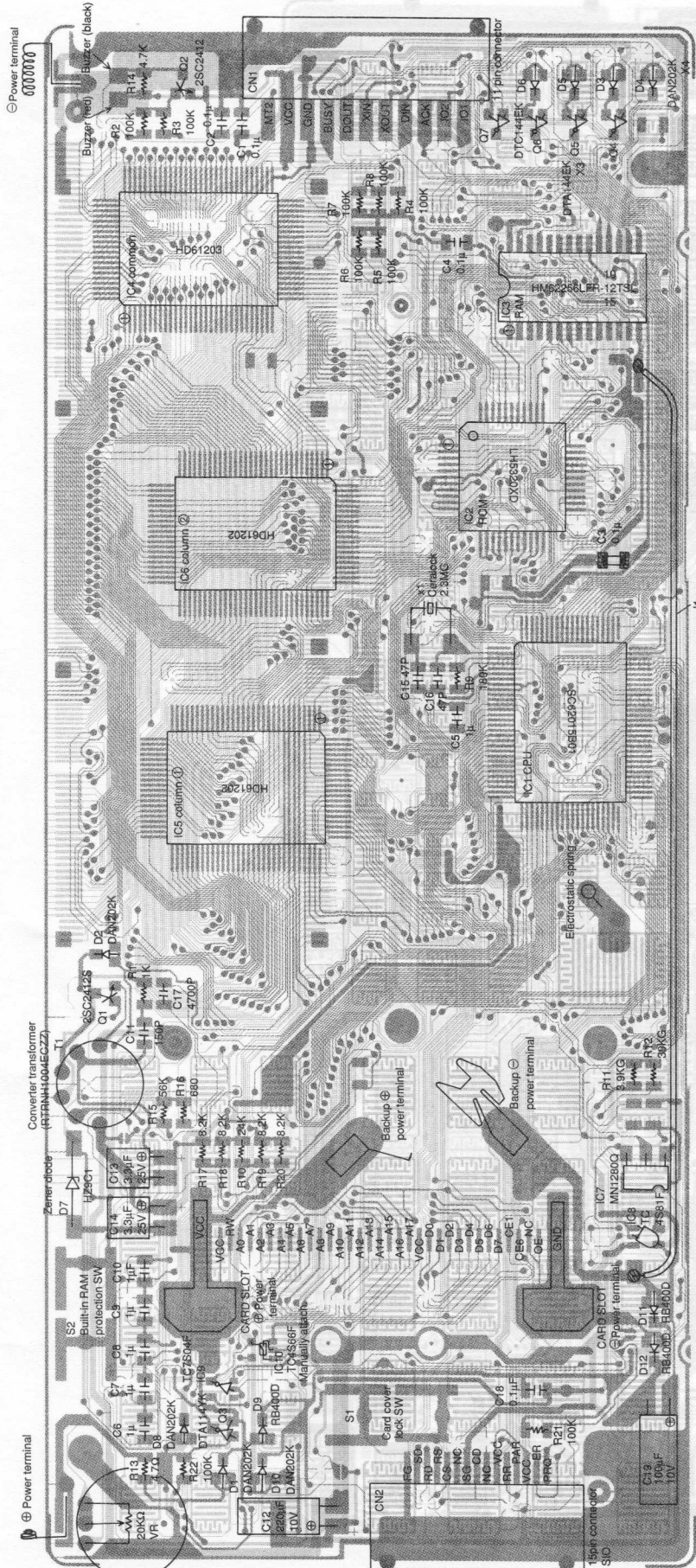

• Solder the IC7 (MN1280Q) without folding its pin as shown in the figure.



• Electrolytic capacitor

• C12, C19 (220µF)

• C13, 14 (3.3µF)

Keep it away from zener diode.



About 4mm

About 7mm

About 2mm

About 120mm

About 2mm

13-2. Key side

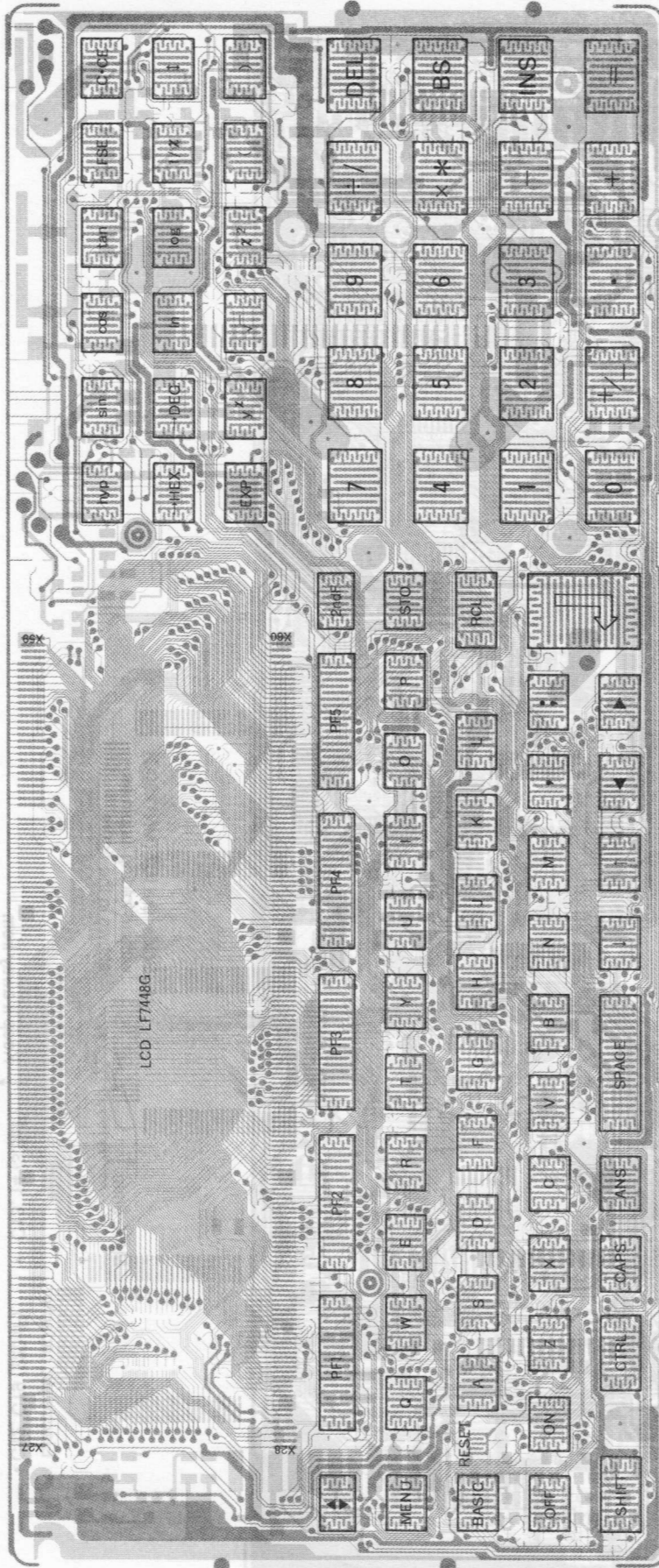

14. Parts list

1 Exterior

NO.	PART NO.
1	GCASP
2	GCABB
3	GFTAA
4	PFLW
5	PSLDP
6	PGUM
7	PGUMM
8	CPWBN
9	DUNT-
10	LX-BZ
11	PGUMS
12	GFTAB
13	PTPEH
14	QTANZ
15	QTANZ
16	QCNTM
17	MSLiP
18	PTPEH
19	RALMB
20	PTPEH
21	GCABA
22	LX-BZ
23	LFIX-
24	TCAUK
25	GFTAU
26	LX-BZ
28	PCUSS
29	PZETL
30	GFTAB
31	LX-BZ
32	JKNBZ
33	TLABH
34	PCUSS
35	TLABH
101	LX-NZ

2 PWB

NO.	PART NO.
1	DUNT-
2	MSPRO
3	MSPRO
4	PGUMS
5	PSPAR
6	PSPAR
7	PZETL
8	QCNCV
9	QCNCV
10	QTANZ
11	QTANZ
12	QTANZ
13	QTANZ
14	QTANZ
15	RC-CZ
16	RC-EZ
17	RCRM
18	RH-DZ
19	RTRN
20	RVR-Z
21	VCCC
22	VCCC
23	VCEA
24	VCKY
25	VHDD
26	VHEH
27	VHiH
28	VHiH
29	VHiL
30	VHiM
31	VHiS
32	VHiT
33	VHiT
34	VHiT
35	VHi6
36	VRS-
37	VRS-

14. Parts list & Guide

1 Exteriors

NO.	PARTS CODE	PRICE RANK	NEW MARK	PART RANK	DESCRIPTION
1	GCASP1006ECZZ	AG	N	D	Hard case
2	GCABB1047EC03	AL	N	D	Top cabinet
3	GFTAA1287CCSA	AB		D	Connector lid (for 15pin connector)
4	PFILW1010ECZZ	AD	N	D	Acryl filter
5	PSLDP1026ECSA	AC	N	C	Display mask
6	PGUMM1031ECSA	AK	N	B	Key rubber B
7	PGUMM1030ECSB	AM	N	B	Key rubber A
8	CPWBN1079EC02	BX	N	E	PWB unit
9	DUNT-1343ECZZ	AY	N	E	LCD unit
10	LX-BZ1109CCZZ	AA		C	Screw (2×4.5)
11	PGUMS1549CCZZ	AE		C	PWB card connector
12	GFTAB1015ECZZ	AB	N	D	Battery lid
13	PTPEH1038EC01	AD	N	C	Shield tape A
14	QTANZ1019ECZZ	AB	N	C	Battery terminal ⊕
15	QTANZ1021ECZZ	AC	N	C	Battery terminal ⊖
16	QCNTM1042CCZZ	AA		C	Slide switch terminal
17	MSLIP1031CC04	AC	N	C	Slider for connector lid
18	PTPEH1039EC01	AB	N	C	Shield tape B
19	RALMB1030CCZZ	AD		B	Buzzer (EFB-S49C02P)
20	PTPEH1213CCZZ	AB		C	Adhesive tape for buzzer
21	GCABA1048EC01	AG	N	D	Bottom cabinet
22	LX-BZ1263CCZZ	AA	N	C	Screw
23	LFIX-1190CCSF	AB	N	C	Fixing plate for card
24	TCAUK1242CCZZ	AA		C	Caution label
25	GFTAUI006ECSC	AF	N	D	Card lid
26	LX-BZ1038CCZZ	AA		C	Screw
28	PCUSS1010ECZZ	AA	N	C	Cushion
29	PZETL1046ECZZ	AA	N	C	Insulation sheet for battery
30	GFTAB1306CCZZ	AD		D	Battery cover
31	LX-BZ1024ECZZ	AA	N	C	Screw
32	JKNBZ1225CCZZ	AB		C	Slide switch knob
33	TLABH1266ECZZ	AC	N	D	Battery replacement label A
34	PCUSS1010ECZZ	AA	N	C	Cushion
35	TLABH1267ECZZ	AC	N	D	Battery replacement label B
101	LX-NZ1020CCZZ	AA		C	Nut (Attach to the top cabinet)

2 PWB unit

NO.	PARTS CODE	PRICE RANK	NEW MARK	PART RANK	DESCRIPTION
1	DUNT-1343ECZZ	AY	N	E	LCD unit
2	MSPRC1007ECZZ	AB		C	Card cover spring
3	MSPRC1277CCZZ	AA		C	Connector spring (for 15pin connector)
4	PGUMS1027ECZZ	AB	N	B	Rubber connector
5	PSPAP1011ECZZ	AA	N	C	Insulation spacer
6	PSPAP1289CCZZ	AA		C	Spacer for 11pin connector
7	PZETL1050ECZZ	AA	N	C	Insulation sheet
8	QCNCW1001EC1A	AG		C	Connector (11pin)
9	QCNCW1368CC1E	AM		C	Connector (15pin)
10	QTANZ1019ECZZ	AB	N	C	Battery terminal ⊕
11	QTANZ1021ECZZ	AC	N	C	Battery terminal ⊖
12	QTANZ1478CCSA	AC		C	Power terminal
13	QTANZ1545CCZZ	AA	N	C	Terminal for memory back up battery ⊕
14	QTANZ1557CCZZ	AB	N	C	Terminal for memory back up battery ⊖
15	RC-CZD105ECZZ	AC		C	Capacitor (1μF)
16	RC-EZ107AEC1A	AB	N	C	Capacitor (10WV 100μF)
17	RCRM-1003ECZZ	AD	N	B	Crystal (2.3MHz)
18	RH-DZ1001ECZZ	AD	N	B	Diode (RB400D)
19	RTRNH1004ECZZ	AK	N	B	Converter transformer
20	RVR-Z2400QCZZ	AF		B	Variable resistor (20KΩ)
21	VCCCTP1HH151J	AA		C	Capacitor (50WV 150PF)
22	VCCCTP1HH470J	AA		C	Capacitor (50WV 47PF)
23	VCEAJU1EW335M	AB	N	C	Capacitor (25WV 3.3μF)
24	VCKYTP1HB472K	AA	N	C	Capacitor (50WV 4700PF)
25	VHDDAN202K/-1	AB		B	Diode (DAN202K)
26	VHEHZ9C1///-1	AB		B	Zener diode (HZ9C1)
27	VHiHD61202/-1	AS	N	B	IC (HD61202)
28	VHiHD61203/-1	AX		B	IC (HD61203)
29	VHiLH5320XH-1	AY	N	B	IC (LH5320XH)
30	VHiMNI1280Q/-1	AE		B	IC (MNI1280Q)
31	VHiSC62015B01	BA	N	B	IC (SC62015B01)
32	VHiTC4S66F/-1	AC	N	B	IC (TC4S66F)
33	VHiTC4S81FTPR	AC	N	B	IC (TC4S81FTPR)
34	VHiTC7S04FTPR	AC		B	IC (TC7S04FTPR)
35	VHi6256LF1XSL	BB	N	B	IC (6256LF1XSL)
36	VRS-TP2BD102J	AA		C	Resistor (1/8W 1.0KΩ ±5%)
37	VRS-TP2BD104J	AA		C	Resistor (1/8W 100KΩ ±5%)

2 PWB unit

NO. PARTS CODE PRICE RANK MARK

DESCRIPTION

NO. PARTS CODE PRICE RANK MARK

DESCRIPTION

NO. PARTS CODE PRICE RANK MARK

DESCRIPTION

NO. PARTS CODE PRICE RANK MARK

DESCRIPTION

NO. PARTS CODE PRICE RANK MARK

DESCRIPTION

NO. PARTS CODE PRICE RANK MARK

DESCRIPTION

NO. PARTS CODE PRICE RANK MARK

DESCRIPTION

NO. PARTS CODE PRICE RANK MARK

DESCRIPTION

NO. PARTS CODE PRICE RANK MARK

DESCRIPTION

NO. PARTS CODE PRICE RANK MARK

DESCRIPTION

NO. PARTS CODE PRICE RANK MARK

DESCRIPTION

NO. PARTS CODE PRICE RANK MARK

DESCRIPTION

NO. PARTS CODE PRICE RANK MARK

DESCRIPTION

NO. PARTS CODE PRICE RANK MARK

DESCRIPTION

NO. PARTS CODE PRICE RANK MARK

DESCRIPTION

NO. PARTS CODE PRICE RANK MARK

DESCRIPTION

NO. PARTS CODE PRICE RANK MARK

DESCRIPTION

NO. PARTS CODE PRICE RANK MARK

DESCRIPTION

NO. PARTS CODE PRICE RANK MARK

DESCRIPTION

NO. PARTS CODE PRICE RANK MARK

DESCRIPTION

NO. PARTS CODE PRICE RANK MARK

DESCRIPTION

NO. PARTS CODE PRICE RANK MARK

DESCRIPTION

NO. PARTS CODE PRICE RANK MARK

DESCRIPTION

NO. PARTS CODE PRICE RANK MARK

DESCRIPTION

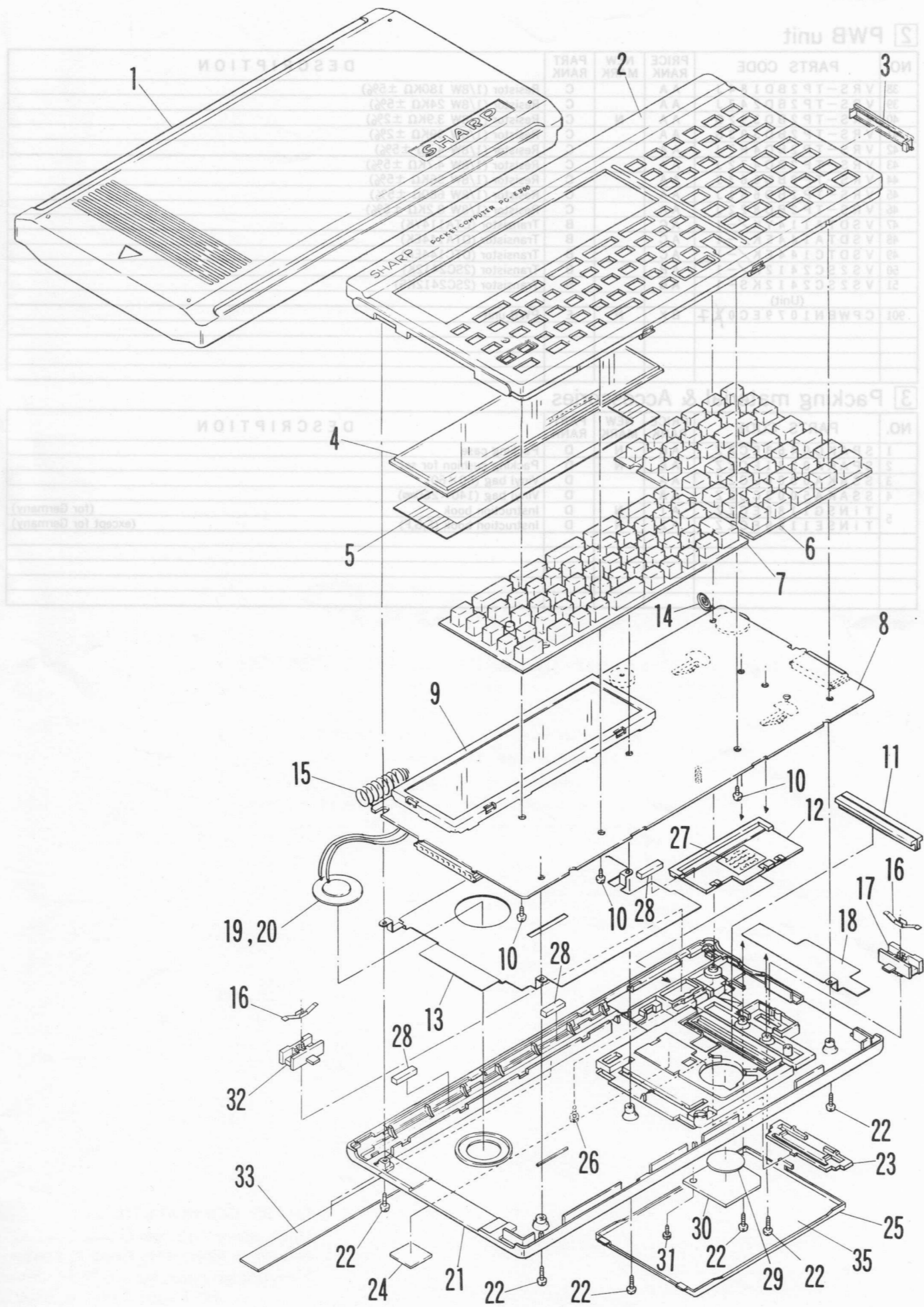

2 PWB unit

NO.	PARTS CODE	PRICE RANK	NEW MARK	PART RANK	DESCRIPTION
38	VRS-TP2BD184J	AA		C	Resistor (1/8W 180KΩ ±5%)
39	VRS-TP2BD243J	AA		C	Resistor (1/8W 24KΩ ±5%)
40	VRS-TP2BD392G	AA	N	C	Resistor (1/8W 3.9KΩ ±2%)
41	VRS-TP2BD393G	AA		C	Resistor (1/8W 39KΩ ±2%)
42	VRS-TP2BD4R7J	AA		C	Resistor (1/8W 4.7Ω ±5%)
43	VRS-TP2BD472J	AA		C	Resistor (1/8W 4.7KΩ ±5%)
44	VRS-TP2BD563J	AA		C	Resistor (1/8W 56KΩ ±5%)
45	VRS-TP2BD681J	AA		C	Resistor (1/8W 680Ω ±5%)
46	VRS-TP2BD822J	AA		C	Resistor (1/8W 8.2KΩ ±5%)
47	VSDTA114YK/-1	AC		B	Transistor (DTA114YK)
48	VSDTA144EK/-1	AC		B	Transistor (DTA144EK)
49	VSDTC144EK/-1	AC		B	Transistor (DTC144EK)
50	VS2SC2412K/-1	AB		B	Transistor (2SC2412K)
51	VS2SC2412KS-1	AB		B	Transistor (2SC2412KS)
	(Unit)				
901	CPWBN1079EC07	BX	N	E	PWB unit

3 Packing material & Accessories

NO.	PARTS CODE	PRICE RANK	NEW MARK	PART RANK	DESCRIPTION
1	SPAKC0463ECZZ	AK	N	D	Packing case
2	SPAKA0381ECZZ	AE	N	D	Packing cushion for set
3	SSAKA0006UCZZ	AA		D	Vinyl bag (50×60)
4	SSAKA5003CCZZ	AA		D	Vinyl bag (140×260mm)
5	TINSG1188ECZZ	AT	N	D	Instruction book (for Germany)
	TINSE1189ECZZ	AZ	N	D	Instruction book (E,G,F) (except for Germany)



